

LE VOYAGEUR

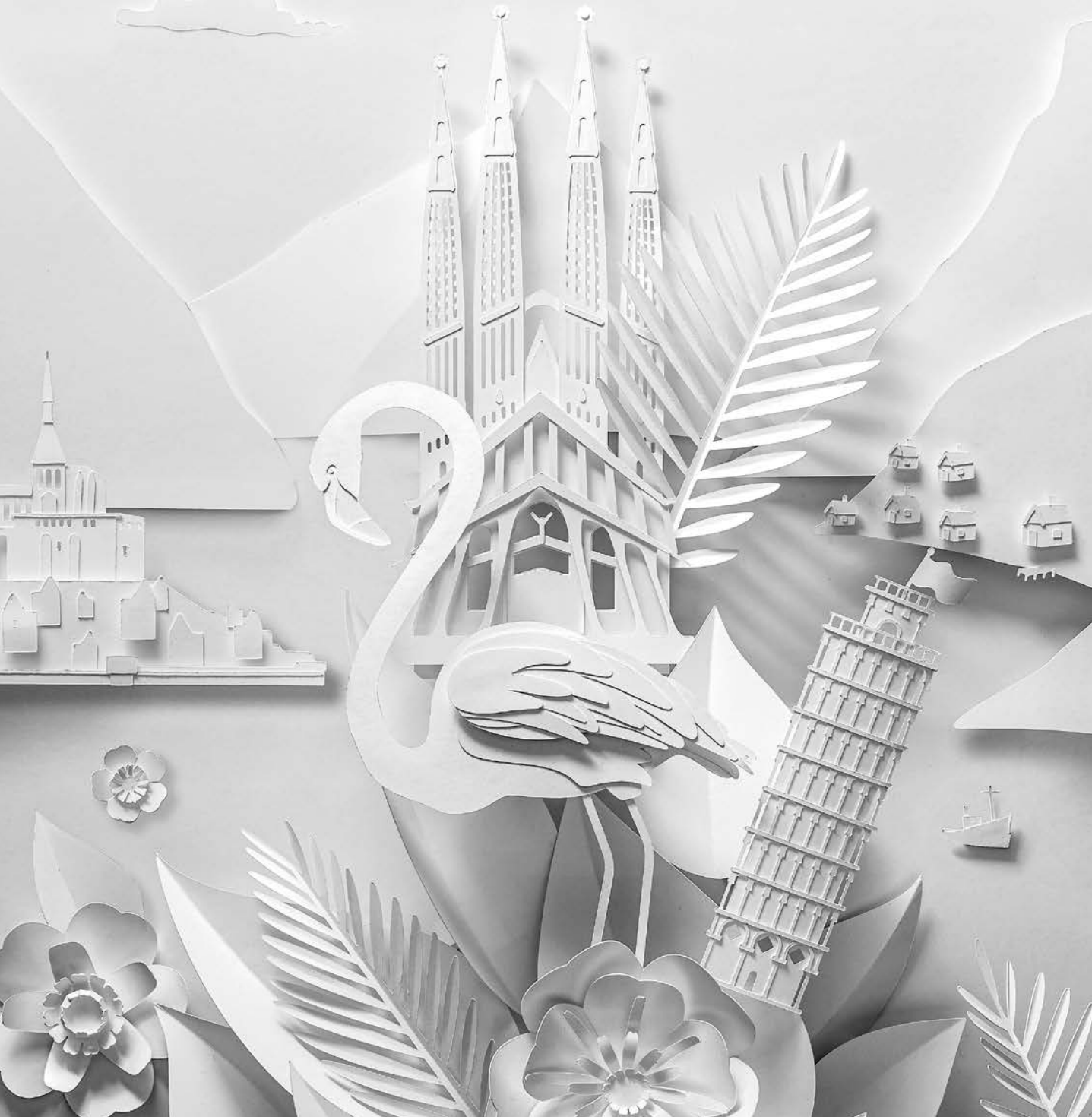





CULTIVATE THE ART OF TRAVEL... FRENCH- STYLE

Climb aboard your LE VOYAGEUR motorhome and kick-start your journey in pursuit of freedom, luxury and pleasure.

The elegance and generosity of its curves, the subtle appeal of its upholstery, and the avant-garde style of its refined, robust bodywork make your motorhome the very essence of French know-how.





WHEN THE EXCEPTION PROVES THE RULE

Travelling is all about leaving reality behind to experience a dream which is even more real. A dream of escape, of exotic destinations where the landscapes defy the imagination, day after day.

But you are no ordinary traveller, you're a Le Voyageur traveller, and you demand nothing less than an incredible, perfect trip.

So you're going to need an ideal travel companion, one who can guide you all around the world in comfort and safety.

That companion is LE VOYAGEUR. As unique and demanding as you when it comes to exceptional travel.









TOGETHER, LET'S BRING THIS DREAM TO LIFE

From dream to reality there's just one step. Tell us your dream and we will make it come true. Do you dream of a light-filled space, a secure and protective cocoon, a warm and welcoming place in which to share precious moments?

Then let's work together to decide what would make your ideal travel companion: dimensions, layouts, equipment, interior styles and finishes... to create something exceptional, you have to dare to break the rules!





EXCEPTIONAL

IS WHAT

WE DO

Driven by a deep desire to perpetuate the excellence of French craftsmanship, our employees have only one objective: to make the exception prove the rule.

From the design office to the workshop, our motorhomes are exclusively developed and manufactured in Angers, western France.

Aerodynamic design, driving comfort, road handling and finishes: to us, every detail matters.

That's why 45 of our leading experts will be needed to turn your dream of perfection into a reality every bit as extraordinary.







"What I love about my job is putting together an exceptional and prestigious product which will satisfy its owner's craving for escape and adventure. I feel that I'm helping in my own way to make this dream come true."

Paul, LE VOYAGEUR dream maker for the last 5 years



"I have always wanted to design a product with real meaning. By co-designing the LE VOYAGEUR with each customer, every detail, every layout is exceptional and unique. I like to exceed myself again and again when planning out the future living space of our customers, and above all sharing their pleasure as they discover their ideal travel companion."

Stéphane, LE VOYAGEUR co-designer for the last 15 years

"Time devoted to my passion, working with materials, making something sublime from them. Shaping, sanding, taking the time to ensure a perfect finish, so that every assembled part helps bring a LE VOYAGEUR to life."

Marie, passionate about LE VOYAGEUR for the last 8 years

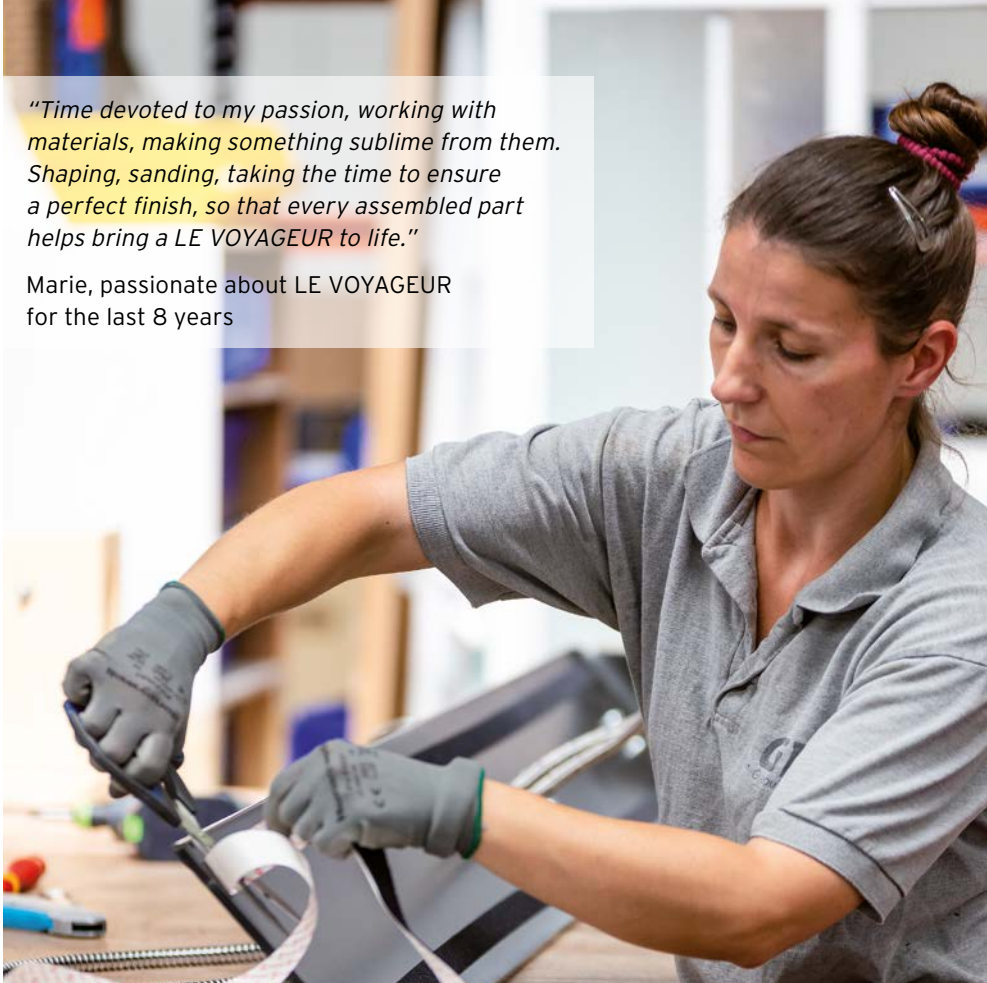

PASSION BREEDS EXCEPTION

Our Classic and Signature ranges are inspired by the wish to create an exceptional vehicle dedicated to satisfying our most demanding customers. However, when it comes to producing something exceptional, know-how and technical expertise alone are not enough. What gives every one

of our motorhomes its unique character is not the purity of its design or the reliability of its technology. Our work is exceptional because it has a soul. The soul of true enthusiasts, always willing to devote their talents and energies to the attainment of genuine perfection.





FABRICATION FRANÇAISE



NOTRE SAVOIR-FAIRE

NOS CAMPING-CARS

NOTRE UNIVERS

NOS CONCESSIONNAIRES



LE VOYAGEUR ET MOI

MON PROFIL

MON VÉHICULE

VIDÉOS D'UTILISATION

CONTACT

PRÉCONISATIONS D'ENTRETIEN

OÙ NOUS TROUVER

Afin de prolonger au maximum l'utilisation de votre LE VOYAGEUR, nous vous prodiguons nos conseils d'entretien

Comment nettoyer le mobilier et le sol ?



Comment nettoyer les éléments textiles ?



Comment entretenir les bales ?



Comment entretenir les sanitaires ?



Comment entretenir le réfrigérateur ?



Comment entretenir le chauffe-eau ?



Comment nettoyer le panneau de contrôle ?



Comment entretenir les aérations ?



Comment laver la carrosserie ?



Comment entretenir la batterie ?



La longévité de la batterie dépend de la manière dont elle est utilisée et entretenue. Veiller à ce que les cosses soient toujours propres et graissées afin d'éviter la sulfatation. Vérifier également que les cosses sont bien serrées. Dès que vous vous absentez à la journée, mettre votre centrale de commande sur « OFF ». Avant de partir en voyage, et notamment après une longue période de non-utilisation, vérifier la charge de vos batteries. Ne pas laisser la batterie déchargée pendant une longue période. Pour pallier ce phénomène, il est nécessaire de ne pas laisser la charge de la batterie descendre en dessous de 11,9 V pendant une longue période, car il y a un risque de décharge profonde, cause d'exclusion de la garantie.

Quand recharger la batterie ?



Comment recharger la batterie ?





LE VOYAGEUR AND ME

Choosing LE VOYAGEUR is your guarantee of a privileged relationship of trust.

With your “LE VOYAGEUR and me” personal area accessible via our website, you can follow every step of the construction of your vehicle.

Video tutorials are provided to help you prepare for its arrival. And, for all your questions, you have priority access to our after-sales service.

LE VOYAGEUR and me will initiate you into all the secrets of your motorhome and the world of LE VOYAGEUR.







CLASSIC[®]

RANGE

LV 6.8 & LV 7.2 P. 22-29

LV 7.5 _____ P. 32-39

LV 7.8 _____ P. 40-47

LV 8.5 _____ P. 48-53

DRIVING REINVENTED

With the new range of FIAT euro 6D engines (140 to 180 hp) and its new nine-speed automatic transmission, you can enjoy optimal driving comfort while also saving money.

Performance is enhanced thanks to an even higher level of torque (as much as +12.5%) while consumption is reduced thanks to VGTs (Variable-Geometry Turbochargers). This system adapts the engine's behaviour to your driving, making your trips both more enjoyable and more environmentally friendly.

To ensure impeccable road handling, our Classic range is equipped with the AL-KO® chassis.





AN INTELLIGENT DESIGN

The intelligent double floor of your Classic motorhome protects you from the cold, ensuring optimal comfort whatever the season. As well as protecting the fresh and waste-water tanks from frost, this double floor, with a height of 26 cm, can be used to store lots of items, thereby freeing up as much space as possible in your LE VOYAGEUR. The walls are mainly composed of aluminium, offering you a 30% improvement in heat diffusion compared to plywood.

Wall-to-wall storage hatches
(as an optional extra: full width
sliding drawer).



THE DOMED ROOF

EXCLUSIVELY IN EUROPE:

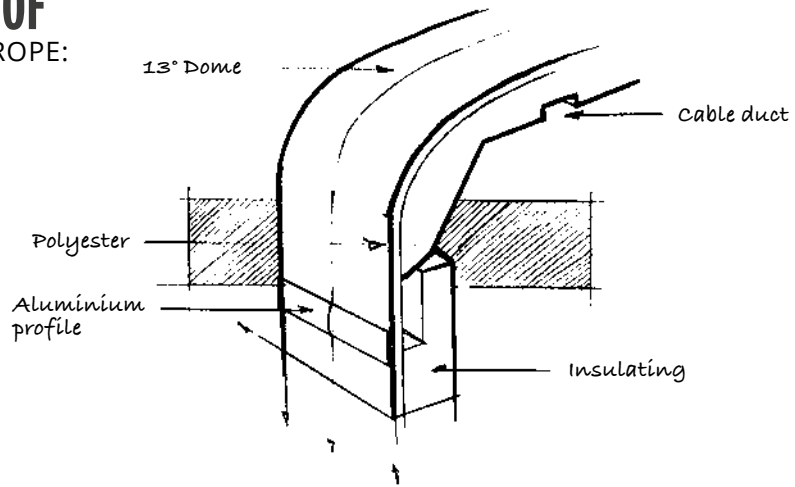

TRAVEL FAR AND WIDE, IN ALL SEASONS

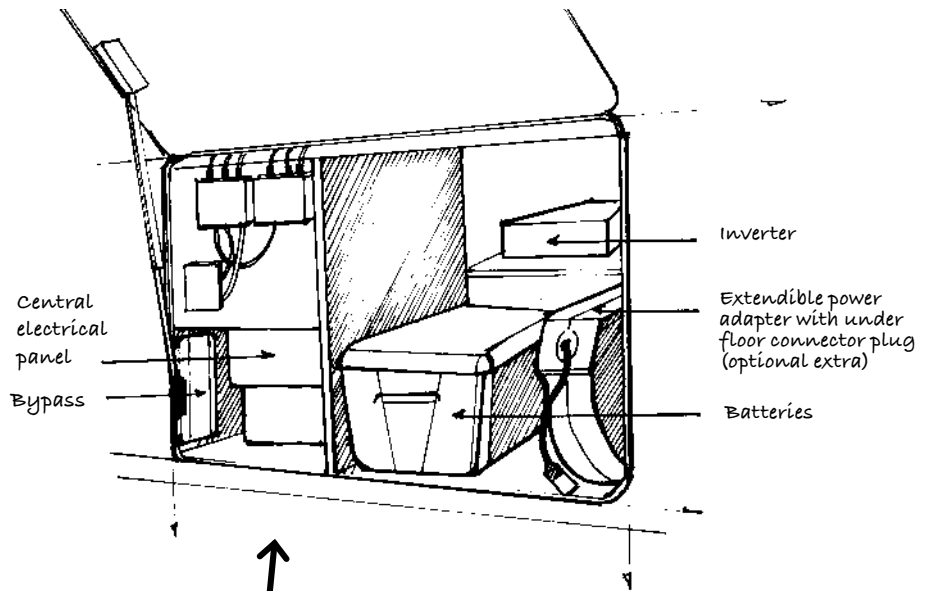

A MULTI-FUNCTIONAL DOUBLE FLOOR

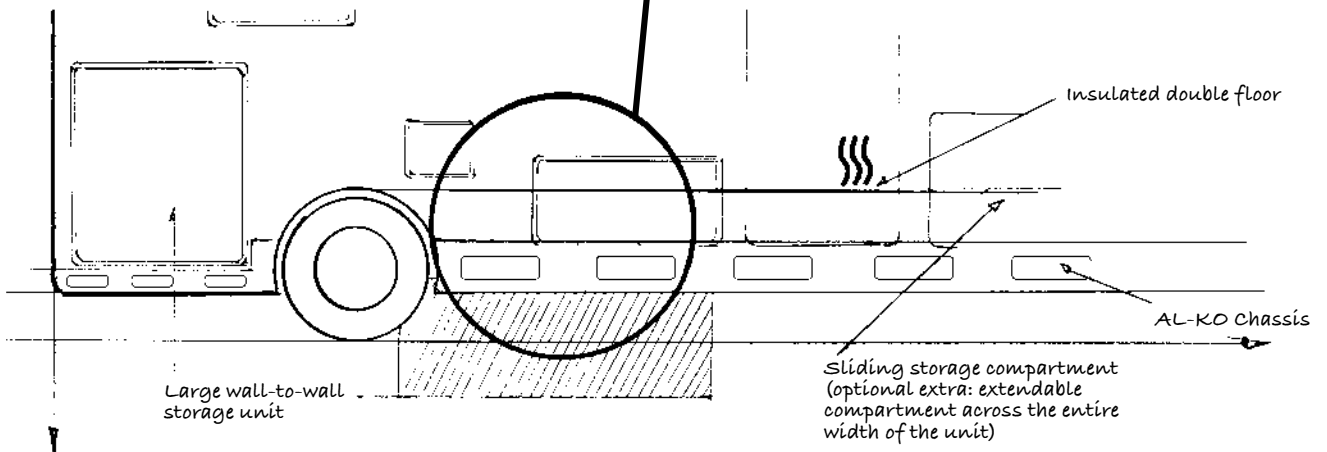

COMFORT AND SAFETY

French luxury is combined with technical expertise to offer you well-being, durability and safety throughout all your travels.

CENTRAL CONTROL UNIT

Choose a single central control unit for managing all the vehicle's functions:

On/Off switch (heating, lighting, radio, television, USB socket, water pump).

- Light dimming by zone
- level indicators (clean water, waste water, leisure battery)
- Truma®/Alde® heating control (Temperature setting, hot water, electric power, gas)

An optional central control connection enables you to manage and operate the motorhome's systems remotely (incl. heating, lighting, radio, TV, water pump) and to monitor the battery and water tank levels.

BYPASS

Ensures continuous operation of key functions (heating, fridge, water pump, LED lighting, 12 V & USB sockets, and step) in the event of central control unit outage.

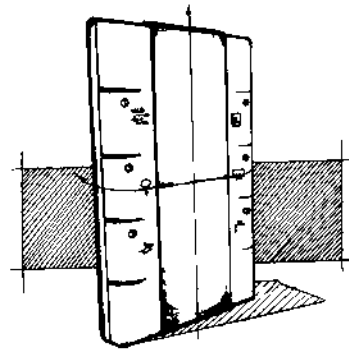

CLASS 3 INSULATION

LE VOYAGEUR is certified Class 3, the best insulation rating on the market, tested and approved by TRUMA® and ALDE®. The interior temperature rises from -15°C to 20°C in less than four hours.

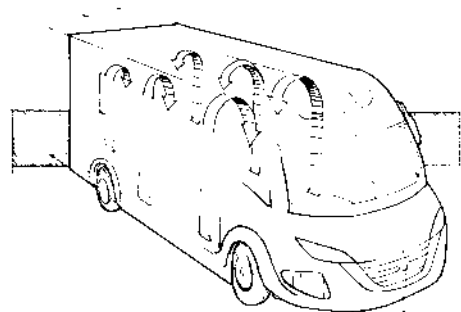

OPTIMUM VISIBILITY

The system is composed of a camera built in to each rear-view mirror and a control screen, divisible into four. The reversing camera is also connected to this screen.

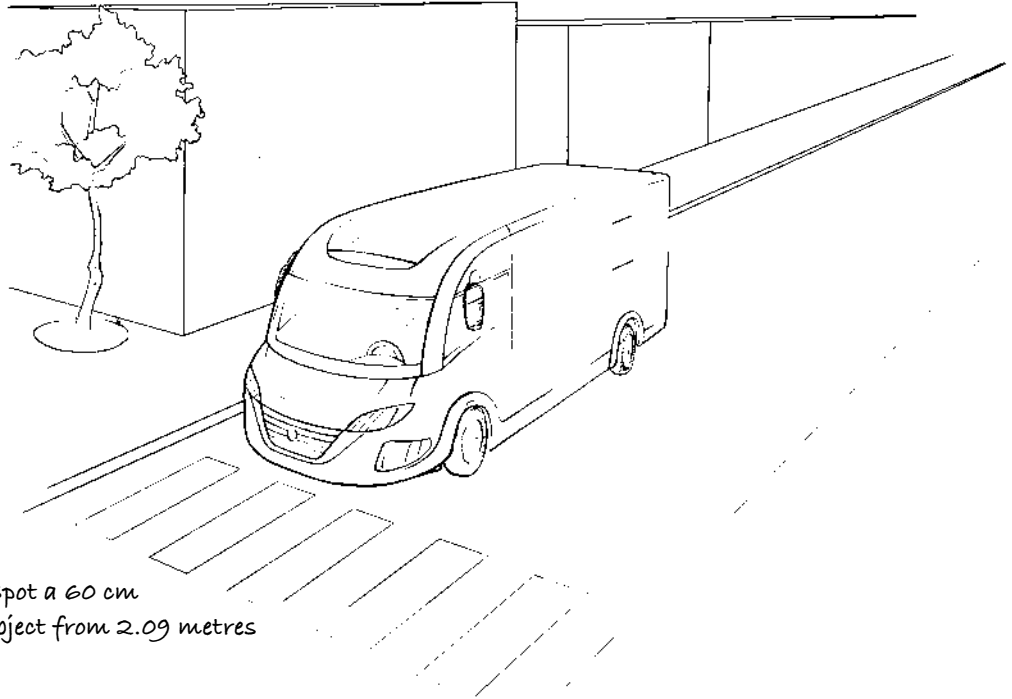

CAMERAS

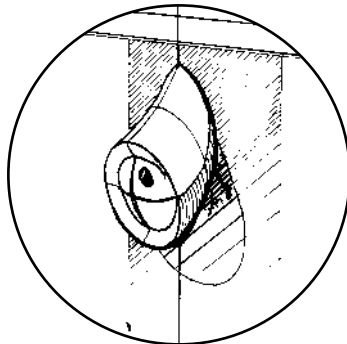

Wide-angle reversing camera

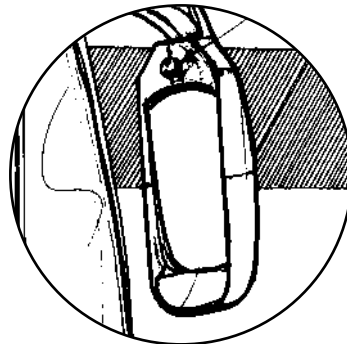

Rear-view mirror camera

LV 6.8

LIGHT-DUTY VEHICLE:
3,500 kg / single axle / 6.80 m

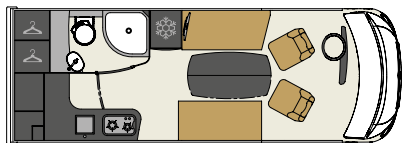

| LV 6.8 LF

LV 7.2

LIGHT-DUTY VEHICLE:
3,500 kg / single axle / 7.25 m

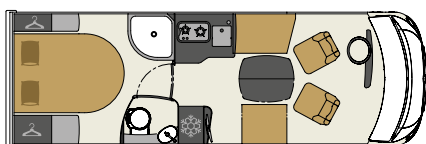

| LV 7.2 CF

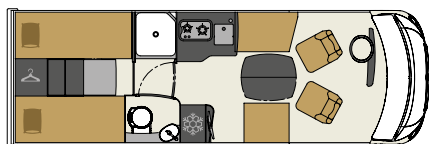

| LV 7.2 GJF

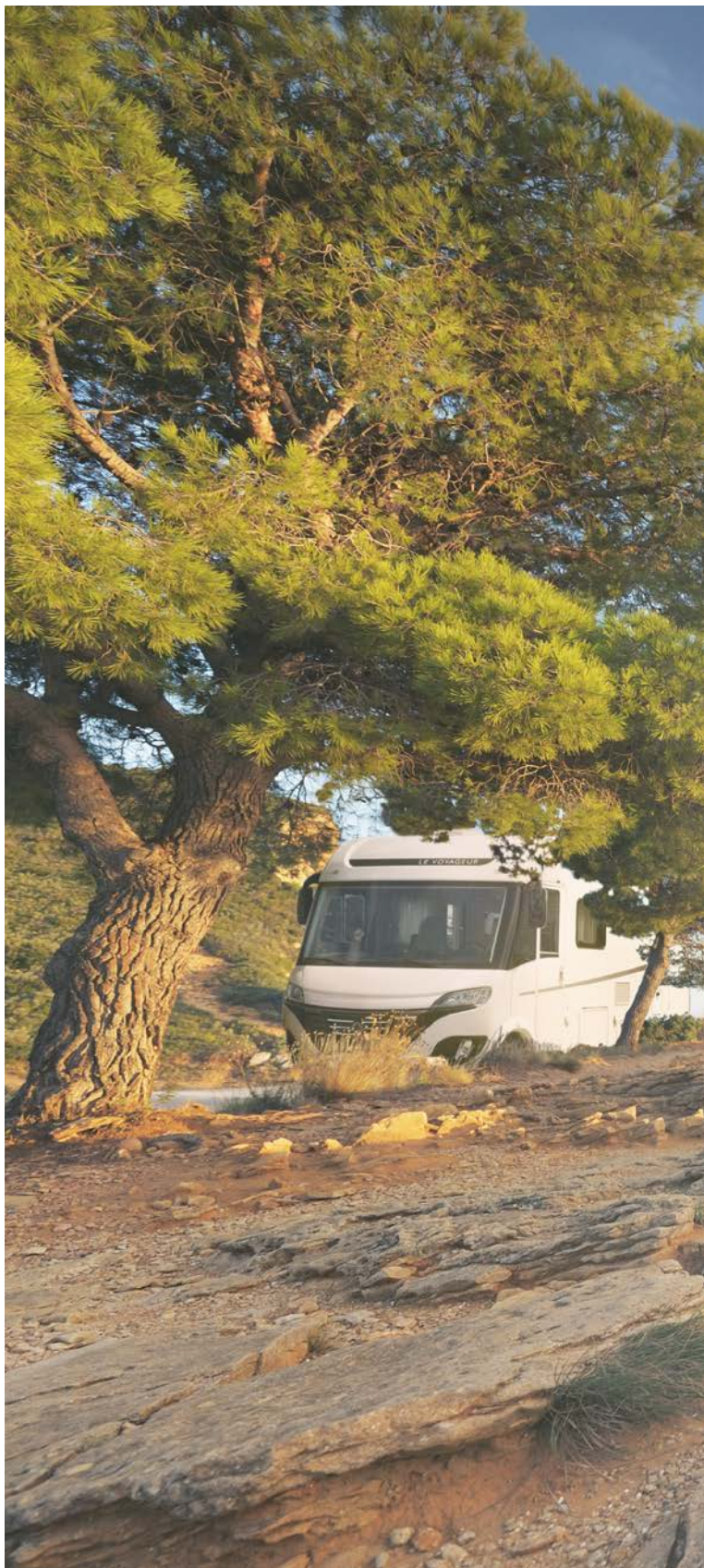

A photograph of a middle-aged couple embracing outdoors. The man, on the left, has grey hair and is wearing an orange long-sleeved shirt. The woman, on the right, has long white hair and is wearing a light blue blouse. They are both smiling warmly. The background shows a clear blue sky with wispy white clouds, green trees on the left, and a rocky landscape with some plants in the foreground. The overall mood is bright and happy.

COMFORT AND SAFETY COMBINED

Light and compact, LV 6.8 and LV 7.2 motorhomes will take you anywhere, even to the mountains.

With its large living areas, the LV 6.8 is like a mini loft apartment, ideal for travelling as a couple.

Available in island bed or twin-bed versions, the LV 7.2 combines everything that is best about French comfort, luxury and quality, and all in a perfectly functional format.



THE KITCHEN

Enjoy the pleasure of cooking in a bright and well-equipped space. The 160 L refrigerator can be used to store all the ingredients you need to prepare dishes worthy of the finest French restaurants.

THE LOUNGE

Spacious and entirely modular, this lounge can be rearranged to suit your needs. Entertaining guests? The face-to-face bench seat and folding table allow you to receive up to six people. Ideal for meals with friends.

The latest addition, available for all vehicles, is the newly designed Dune finish, as warm and relaxing as an afternoon at the seaside.







THE BEDROOM

With its built-in wardrobe and laundry unit, electrically retractable island bed with Bultex mattress, and its LED night-time guide light system, this spacious and fully equipped bedroom will make all your dreams come true.



THE KITCHEN

Enjoy the pleasure of a kitchen just like at home thanks to a perfectly ergonomic space. Whether preparing a salad, cooking in the oven or frying in the pan, your kitchen meets all your needs.

Laminated top with a large working area, double cooking hob, new mixer tap with anti-drip swivel head in the Classic and Signature range, backsplash equipped with 12 and 230 V sockets, storage compartment with hatch on the double floor... Everything you need for cooking under optimal conditions.



THE BATHROOM

After an action-packed day, take some time out to relax in your impeccably designed bathroom. Its 190 cm shower provides all the comfort you need. A locking swing door allows you to have a separate toilet space.







LV 7.5

HEAVY-DUTY VEHICLE:
4,500 kg / single axle / 7.55 m

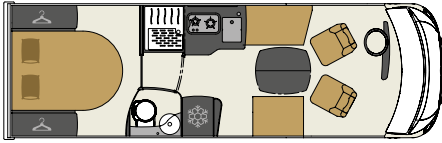

| LV 7.5 CF

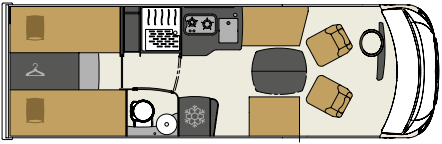

| LV 7.5 GJF

FEEL RIGHT AT HOME, WHEREVER YOU GO

The LV 7.5 offers the perfect combination of real comfort and easy movement. The separation of its different living areas provides the feel of an apartment, so much so that you'll want to make this your motorhome away from home.

With an exceptional load capacity of 1,000 kg, this luxury travel vehicle may be heavy duty, but it remains easy to manoeuvre.

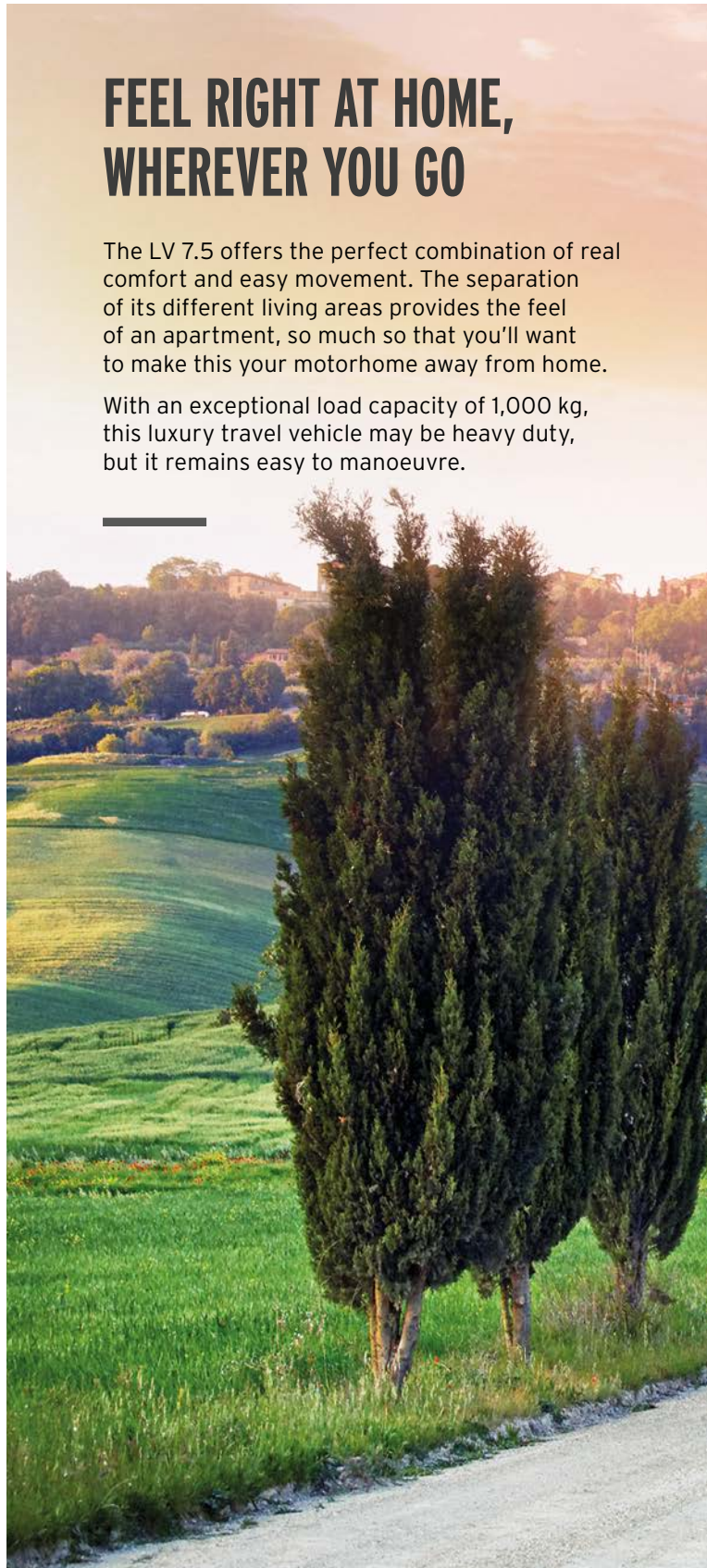







THE BEDROOM

To preserve your privacy, the bedroom is separated from the other areas by a door. Twin beds, mattress extension, electrical or manual retraction, various bed heights... Discover all the options we offer to make your bedroom a cosy little nest.



THE LOUNGE

Luxury is reflected in the well designed interior, with room for everyone to move around freely and find their own space. The face-to-face bench seat can hold up to five people, and conceals a longitudinal drop-down bed as an optional extra.









THE BATHROOM

Enjoy the separate bathroom, equipped with a double bedroom/lounge partition. Its sleek design will bring you a real sense of wellbeing in this functional space, ensuring that those little everyday moments enhance the simplicity of your travels.

THE KITCHEN

If cooking is to be a real pleasure, there are some things every kitchen needs: four shelves, a brand new mixer tap with anti-drip swivel head, a 160 L fridge, and a backsplash equipped with 12 and 230 V sockets. The perfect space for culinary masterclasses with family or friends.



LV 7.8

HEAVY-DUTY VEHICLE:
4,500 kg / single axle / 7.85 m

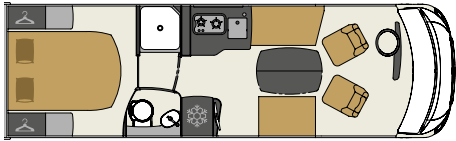

| LV 7.8 CF

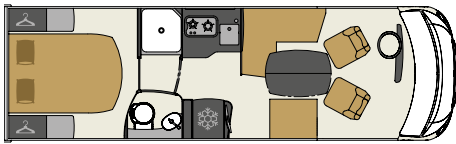

| LV 7.8 CL

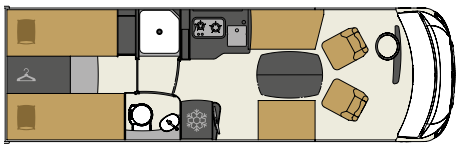

| LV 7.8 GJF



| LV 7.8 GJL

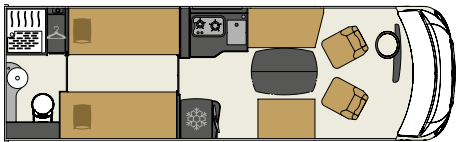

| LV 7.8 JF

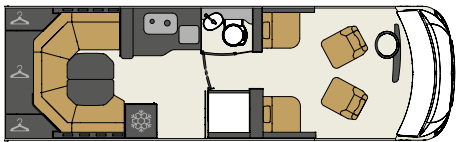

| LV 7.8 LU - NEW LAYOUT





SIMPLE, MEASURED LUXURY

If you dream of wide open spaces, incredible panoramic views, and the kind of comfort you enjoy in your own home, your 7.8 can offer you all this and more.

The entirely modular interior can be adapted to suit your preferences thanks to a very wide choice of layouts. With lots of ergonomically arranged storage units, you can enjoy the convenience of bringing everything with you, without having to think twice.

And our latest addition, the U-shaped lounge, allows you to admire the landscape through its large window, offering a stunning view of the outside world.

THE LOUNGE

Exclusive to the 7.8 and a major new addition in 2020, the U-shaped lounge can accommodate up to six people. Its large rear window provides an exceptional panoramic view and excellent luminosity. Featuring two wardrobes with automatic lighting, it offers maximum storage capacity. This is also the only lounge model to include a 32" HD LED screen built into a custom-fitted electrical rising unit.

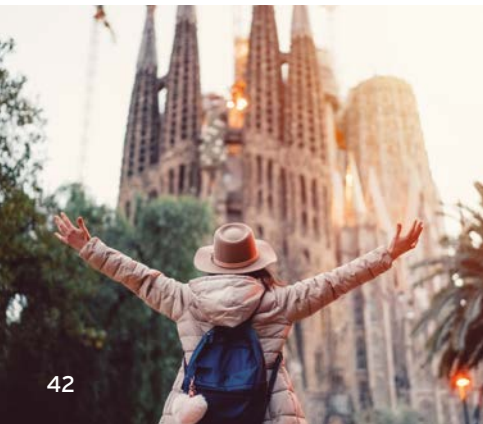





THE KITCHEN

This is a well designed space, perfect for cooking under optimal conditions. Its full-height sliding unit composed of four shelves provides lots of storage capacity. What's more, each kitchen unit is fitted with Hettich runners for soft and silent movement.

There is also a three-speed extractor hood, fully touch-sensitive controls, LED lighting and timer, a 160 L fridge, a backsplash equipped with 12 and 230 V sockets, and the latest new feature, the mixer tap with anti-drip swivel head.

THE BATHROOM

Elegant and functional, ergonomic and well equipped, the bathroom should always be a pleasant space, with the focus on comfort. With its large 190 cm shower and its numerous storage units and shelves, the separate bathroom will ensure your wellbeing and privacy.







THE BEDROOM

As a new option, the electric longitudinal drop-down bed is now available in all Classic and Signature vehicles. Measuring 2 x 2 m, this sleeping area provides the option of sleeping along the length or width of the vehicle, as you prefer. In summary, this is a simple and intelligent sliding system for nights of luxury, comfort and tranquillity.

LV 8.5

HEAVY-DUTY VEHICLES:
5,000 kg / double axle / 8.55 m

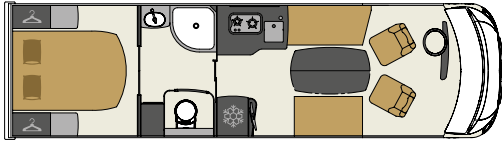

| LV 8.5 CF

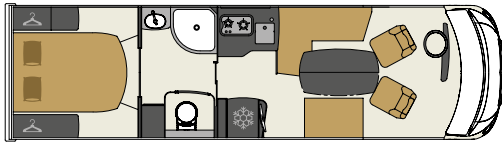

| LV 8.5 CL

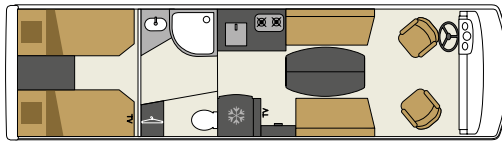

| LV 8.5 GJF

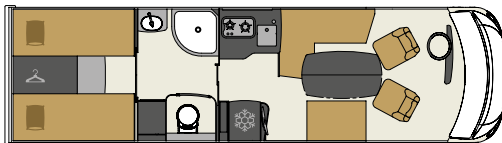

| LV 8.5 GJL

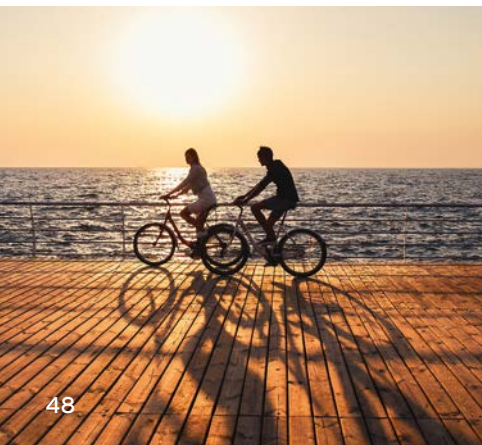

TRAVEL BEYOND THE HORIZON

The 8.5 is known as Le Prestige thanks to its ability to always offer that little bit more.

Available in four different layouts, with an XL hold and a dining area

for six guests, the 8.5 favours generous dimensions. With the added stability that comes with the double axle, this vehicle offers unrivalled comfort thanks also to the generous volume of its living spaces.





THE KITCHEN

Ergonomic design and reliable equipment are the essentials of any kitchen. With its two hobs, mixer tap with anti-drip swivel head, backsplash equipped with 12 and 230 V sockets, and Turbovent for optimal ventilation, the kitchen in the 8.5 has all the essential ingredients for a pleasurable cooking experience.

THE LOUNGE

Elegant and cosy, the lounge area of the Classic 8.5 motorhome offers a luxurious relaxation space for you and your guests. With its face-to-face bench seat for up to six people and its wide circulation areas, it is ideal for impromptu evenings with friends.







THE BEDROOM

As a central element in any living quarters, the bedroom is a private area which should always be bright, cosy and comfortable. With its island bed equipped with a Bultex mattress and a headboard which can be raised to free up more space, the bedroom of the 8.5 meets all your needs.

THE BATHROOM

The bathroom of your Classic 8.5, as well as being separate from the bedroom and lounge, also offers you the privacy you need, being insulated from the toilet by a swing door. Its warm and cosy atmosphere is ideal for enjoying a relaxing evening after a day full of discoveries and adventures.







SIGNATURE[®]

RANGE

18.0 & 18.5 _____ P. 60-75



AN UNRIVALLED DRIVING EXPERIENCE

The Iveco® Euro 6D engine boasts a more powerful alternator (220 amps) for faster battery charging. Thanks to its assisted steering, manoeuvring your motorhome is easy, wherever you are. Eight-speed automatic transmission, assisted steering, hill start assist, active tyre pressure monitoring... all these features ensure smooth and economical driving. To offer you perfect visibility, its leather steering wheel adapts to your body shape (height and depth adjustable). Similarly, the High Connect car radio will convert your smartphone into a real control centre, which is simple to use and entirely secure.



EXCEPTIONAL ROAD HANDLING

Permissible load in the hold: 600 kg

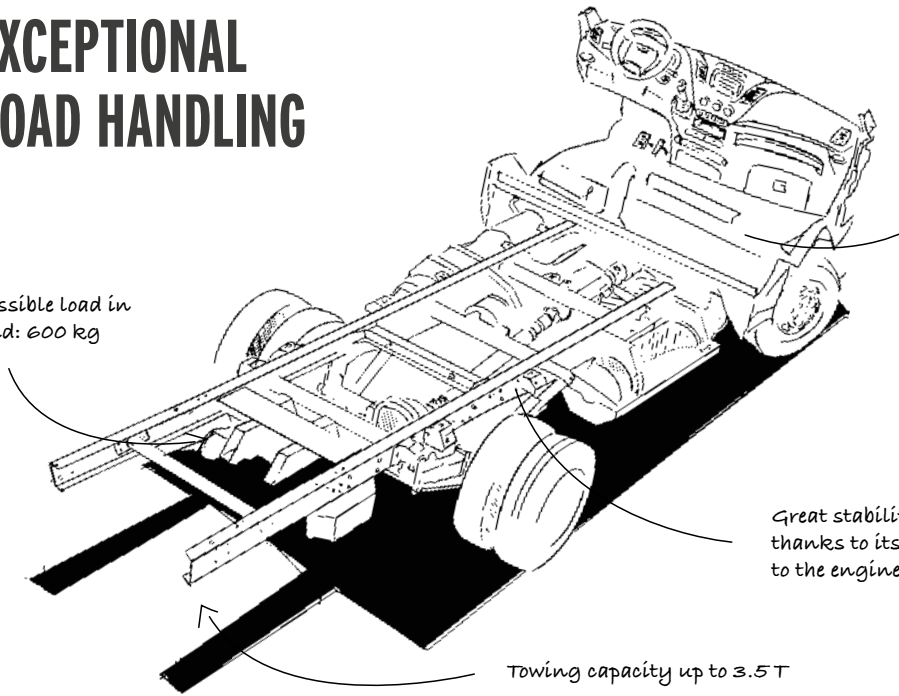

Propulsion = Small turning radius

Great stability and comfort, thanks to its backbone chassis up to the engine

Towing capacity up to 3.5 T



ENERGY

AUTONOMY

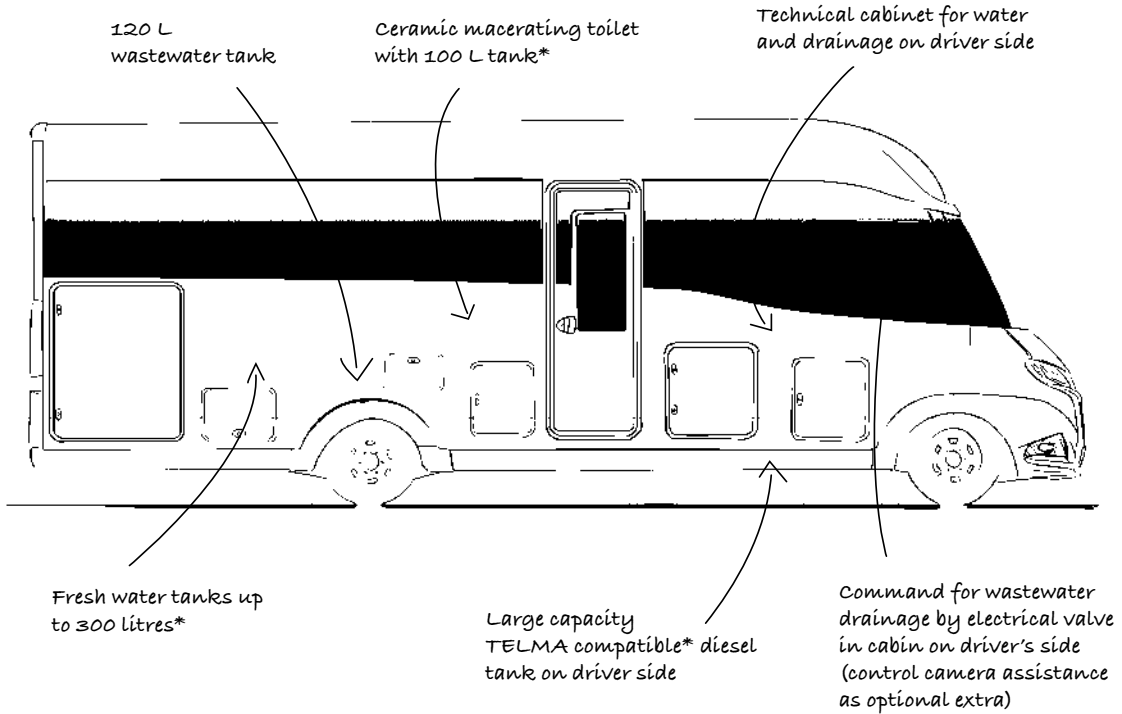

NEW INVERTER

Renowned in the sailing sector, the new 1600 W inverter has been thoroughly tried and tested in terms of its performance.

Powerful and agile, it pushes the boundaries of autonomy and allows greater versatility for simultaneous use of devices. It includes a pure sine inverter, an adaptive charger and hybrid PowerAssist technology.

This new inverter is also available in the Classic range.

SMART VISION

Smart Vision is an entirely unique rear-view system which replaces traditional rear-view mirrors with high-definition cameras and control screens positioned inside the vehicle. Blind spots are eliminated, risks of lateral collision are reduced, and manoeuvring is made easier, day or night. Whatever the weather, it uses technology to eliminate reflections, mist, and glare from sun or headlights. The system also includes a surveillance mode which monitors the area around the vehicle while parked. Latest addition (optional extra), overtaking assist: the system configures itself to the length of the vehicle for perfectly smooth driving.

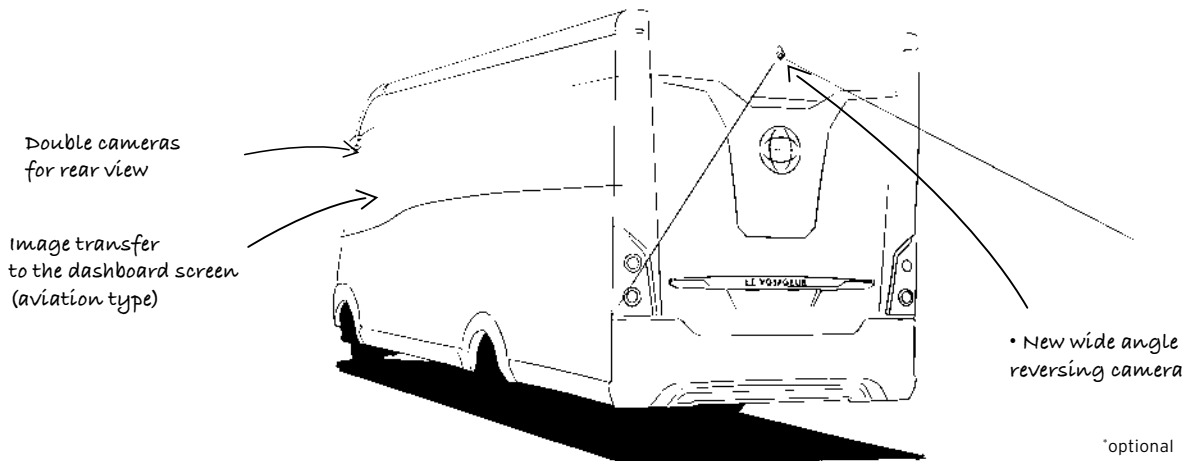
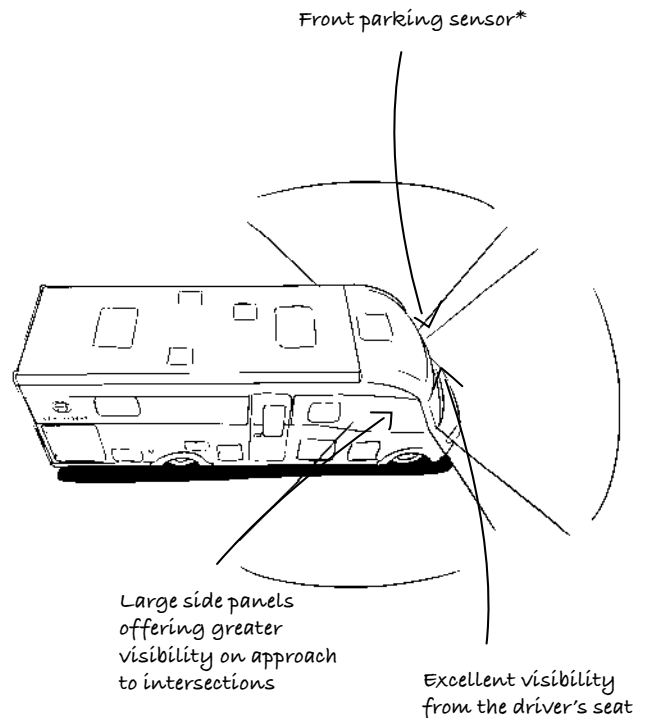

18.0

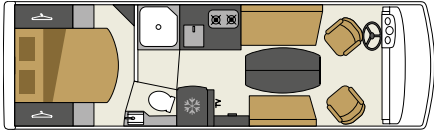

| 18.0 CF

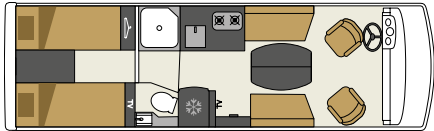

| 18.0 GJF

18.5

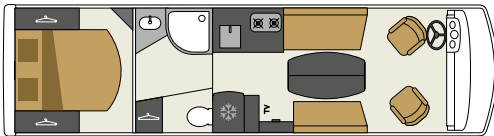

| 18.5 CF

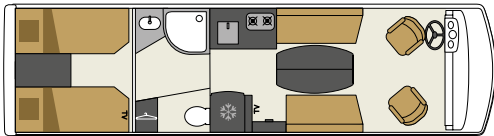

| 18.5 GJF



TRAVEL WITHOUT LIMITS

The Signature I8.0 and I8.5 motorhomes have been designed to be tireless travel companions. Offering style, reliability, comfort and safety, they both have a single objective: to give you an exceptional travel experience.



18.0 CF





THE BEDROOM

Equipped with reading lights and storage compartments, the island bed allows you to read or watch television in optimal comfort. In raised position, the backlit headboard with embroidered logo gives more circulation space. In addition to the cupboards, the dressing table and bedside cabinets offer lots of storage space.







THE LOUNGE

In the interior, the fine materials lend the Signature a unique atmosphere. The numerous storage units are practical and cleverly arranged, as well as being accessible from both inside and out. Choosing the furnished option instead of a drop-down bed makes it possible to maximise these storage spaces. Take time out to enjoy a tasty snack with your friends on your comfortable face-to-face bench seat.







THE BEDROOM

Enjoy pure tranquillity in a bedroom decorated in subtle, soothing colours. Its twin beds with an optional electrical wall retraction system free up more space. The backlit headboard and pre-wired TV point will be perfect for reading or watching your favourite programme.





THE BATHROOM

A wide corridor leads to the bathroom, equipped with a 190 cm high shower, a large recessed resin washbasin and a handy little shelf for your shower products.





18.5 GJF





THE LOUNGE

In your XXL lounge, enjoy a friendly get-together on the very comfortable face-to-face bench seat. The 2 x 2 m longitudinal drop-down bed is simple to set up, perfect for hosting your guests at the end of the evening. The new Dune finish will brighten your lounge with its warm and subtle colours.

18.5 GJF





THE KITCHEN

Functional and bright, your kitchen comes with a vast resin worktop, a chrome mixer tap with aerator, and a saucepan drawer with partitions and dividers. Amass your own wine collection with a sliding rack holding up to eight bottles. Prepare gourmet dishes for your dinner guests in your superb built-in oven. Subtle and elegant, it fits perfectly into your overall kitchen layout.

INTERIOR CUSTOMISATION

UPHOLSTERY



Charme satin - imitation leather (optional)



Élégance brun - mixed leather + fabric (optional)



Charme cachemire - imitation leather (optional)



Chic brun - mixed imitation leather + fabric (optional)



Prestige vison - 100% leather (optional)



Soft brun - fabric (standard)



Prestige satin - 100% leather (optional)

WOODWORK



Cognac



Dune

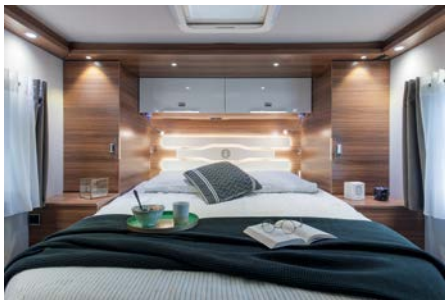

Official seating classification and Mass in Running Order are calculated as accurately as possible in compliance with European legislation. These take basic and standard equipment into account with a tolerance of +/- 5%. Mass In Running Order figures include freshwater tanks, as indicated in the "Fresh water on the road" technical evaluation grid, and diesel tanks 90% full, one gas bottle 90% full, but do not include the weight of the driver or other occupants. Available load capacity figures are the difference between Maximum Technically Permissible Laden Mass and Mass In Running Order. The manufacturer undertakes to provide a motorhome with an actual Mass In Running Order within the 5% tolerance of the indicated Mass In Running Order used for type approval. Caution: additional optional equipment and accessories are not included in motorhome Mass in Running Order figures. Consequently, these will systematically lead to a reduction in available load capacity. Similarly, the significant weight of the additional accessories offered on the market must also be deducted from the motorhomes' available load capacity. Consequently, fitting such accessories may require a reduction in passenger numbers. Compliance should therefore be ensured with all maximum authorised mass figures (total and per axle) once the vehicle is fully laden. Maximum towing limit is chassis data linked to the type approval of the vehicle. Depending on the kind of tow-hitch to be fitted to the vehicle and the specific values given by the tow-hitch manufacturer, the maximum mass of any trailer that may be towed by the vehicle may be lower. Tow-hitch strength ratings (especially values D and S) are stamped on a plate fixed to the tow-hitch. D enables the maximum towing weight to be calculated using the following formula: $MTL = \frac{D \times T}{(9.8 \times T) - D}$, where: MTL = maximum towing limit (in tonnes); T = Gross Vehicle Weight (GVW) (in tonnes); D = value (in kN) taken from tow hitch. E.g.: if D = 11.3 kN for a 35 L base, the maximum towing limit (MTL) will be the following: $MTL = \frac{11.3 \times 3.5}{(9.8 \times 3.5) - 11.3} = 1.72$ tonnes (or 1,720 kg) for a maximum towing limit for a vehicle that can be up to 2.5 tonnes. Motorhomes complying with the technical and design specifications presented in this brochure are considered to be part of the 2020 collection if registered after 1 July 2019. This rule is commonly applied to motorhomes, where the concept of 'model-year' does not exist. The vehicles photographed in this catalogue may include optional equipment subject to extra cost. As Le Voyageur vehicles are sold in several EU countries, their technical specifications and equipment may vary from one country to another. For the exact specifications of models available in each country, please contact your LE VOYAGEUR dealer. Le Voyageur reserves the right to alter the vehicles described in this brochure at any time and without notice. Although every care has been taken in its production, this catalogue does not constitute a contractual document.





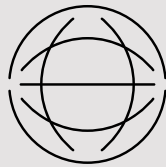

LE VOYAGEUR

THE EXCEPTION THAT PROVES THE RULE

With the production of the original model in 1981, George Sacier, creator of the first LE VOYAGEUR, pushed the limits of what was possible to realise his dream: designing a vehicle able to take you as far as your dreams could stretch.

This passion for design, luxury and performance are still evident in today's LE VOYAGEUR luxury motorhomes, which enable mobility without borders.

www.levoyageur-motorhome.uk